

# Flapper Position Reference Guide

The following chart displays which flapper should go in which of the six positions on the rotor for each of the five Flow-Rite valves. Use of this chart is only necessary if you do not know the positions of your original flappers.

		Rotor Position #					
		1	2	3	4	5	6
Valve #	V1			B			B
	V2					A	A
	V3		B		A		A
	V4					B	B
	V5		B	B			

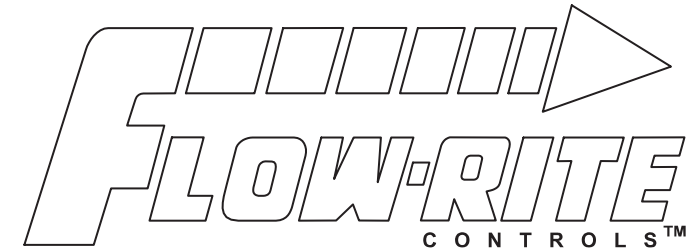
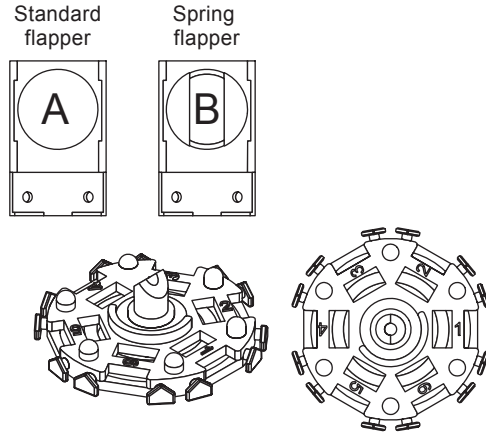

# FLAPPER REPLACEMENT GUIDE

## Older Model Valves

It is possible that you will have one of our older model valves containing one of the following rotors. The positions on these rotors are not numbered, therefore, we have included the following diagrams for your reference.

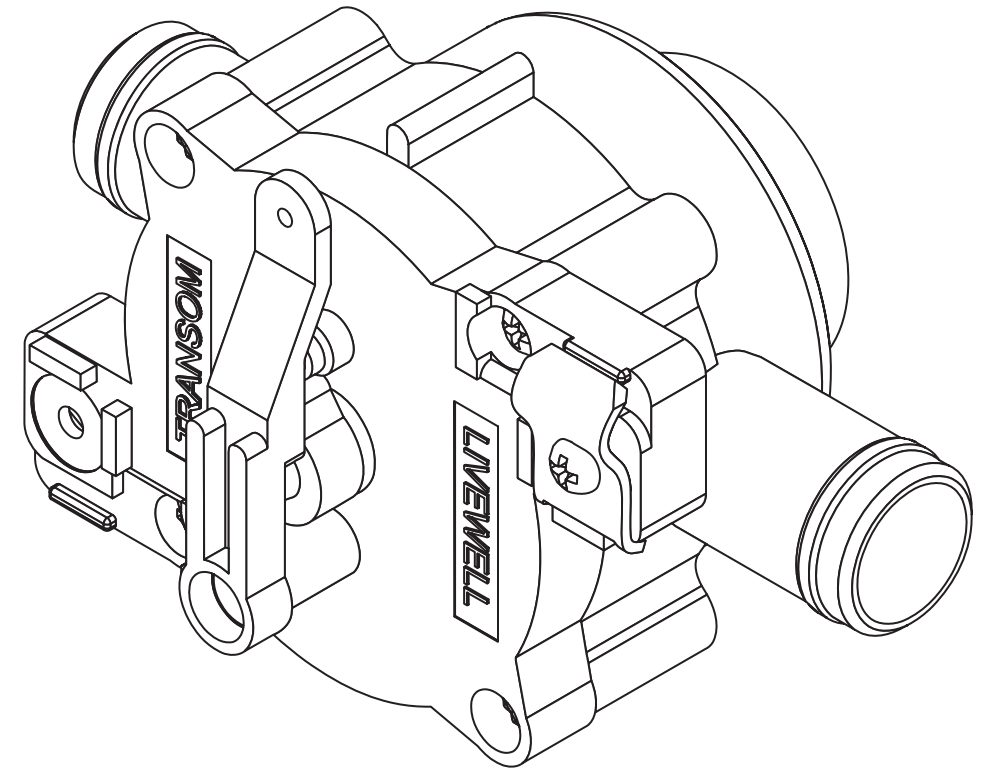
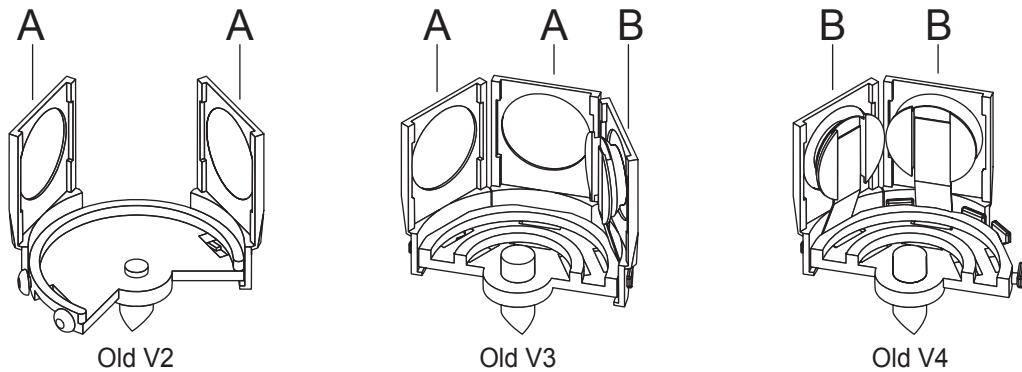

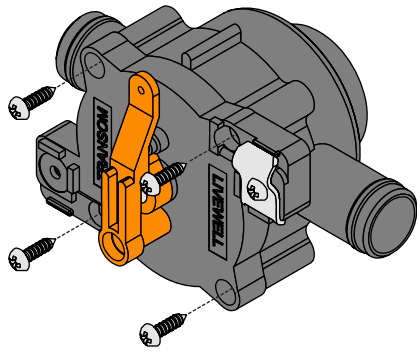

**Step 1**

Remove the four valve cap screws. *Important: Do not over tighten screws when reassembling.*

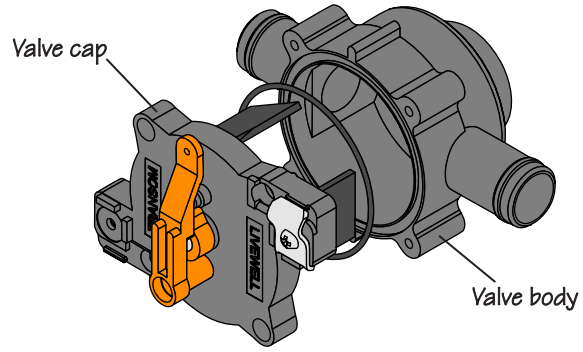

**Step 2**

Pull valve cap from valve body. Note the proper position of the large O-ring between the cap and body.

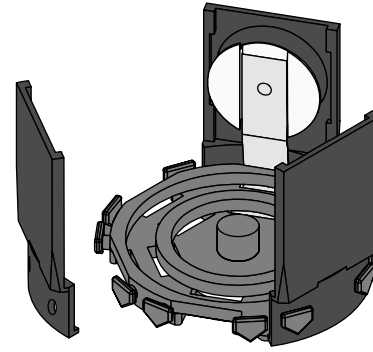

**Step 5**

Remove the old flappers from their button mounts on the rotor.

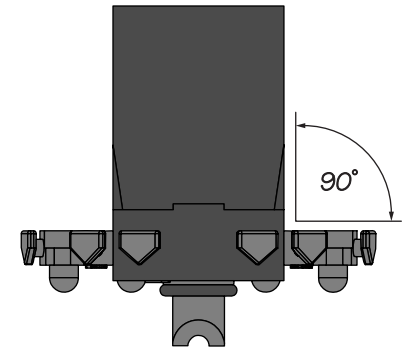

**Step 6**

Place the new flappers into position. Be sure that the flappers are square to the rotor.

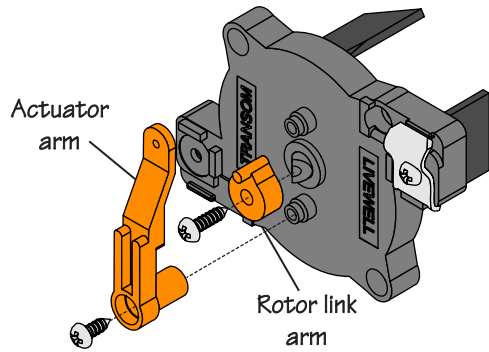

**Step 3**

Remove the actuator arm and the rotor link arm. Note that the small screw is for the large arm and the large screw is for the small arm. *Important: Do not over tighten screws when re-assembling.*

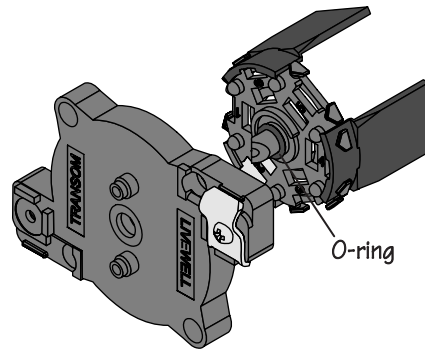

**Step 4**

Push the rotor/flapper assembly out of the valve cap. Note the proper position of the small O-ring on the rotor stem.

