

Contents
(1) Eagle Eye Level Light
(1) Self-Tapping Screw, SS
(1) Grommet
(1) Instruction sheet

Tools Required
Drill
Approved 1/2" Drill Bit (p/n: BA-107)
1/4" Nut Driver
Dielectric Grease

Specifications
Max current draw: 20 mA
Nominal operating voltage: 12VDC
Operating Temperature: 0-180 ° F

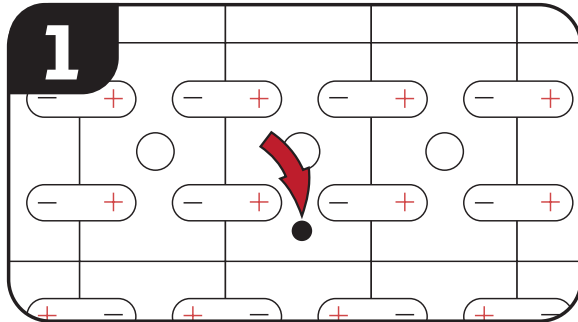

Choose probe location near the center of the battery. Drill 1/2" diameter hole in the cell cover with approved drill bit. Make sure there is clearance down to the plates and around the probe before drilling.

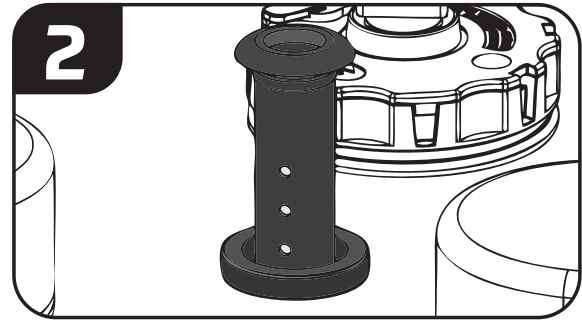

Place the gauge guard into the drilled hole until it stops. Count the number of visible holes on the gauge guard. If the guard does not have any visible holes, remove the guard and proceed to step 4.

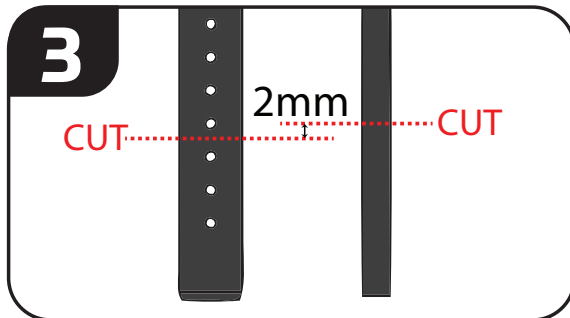

Count the same number of holes on the gauge guard starting from the bottom and cut the gauge guard at this height. Cut the sensor probe 2mm shorter than the gauge guard, then strip the heat shrink of the probe by approximately 5mm.

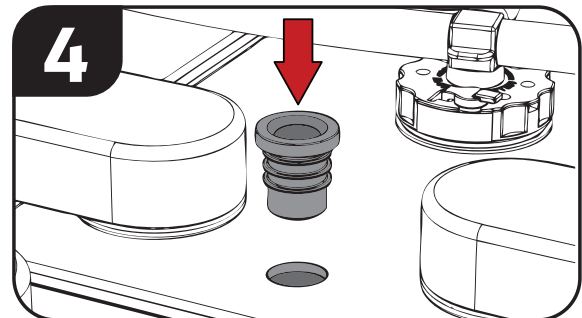

Install grommet into cell.

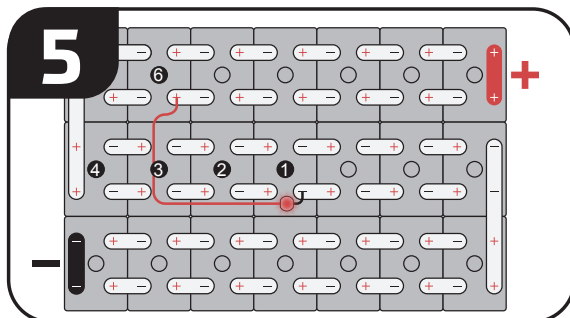

Select cell post locations for wire installation. This will require 6 cells in series with the black wire attached to the negative terminal into which the sensor is installed and the red wire attached to the positive terminal six cells up.

*NOTE: The wires should not be pulled tight.*

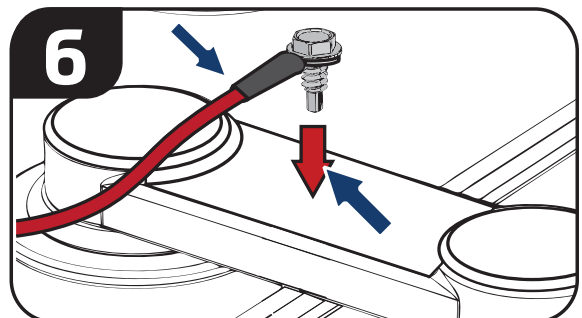

Remove the terminal shroud and screw the positive wire lead directly into the positive terminal with the included self-tapping screw.

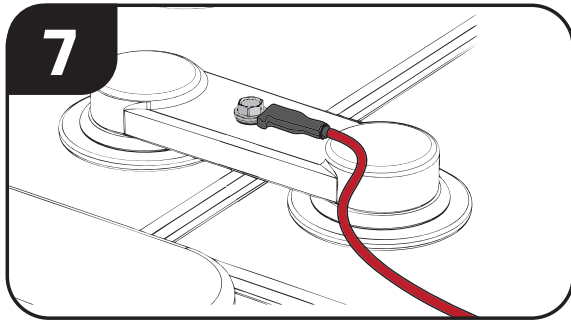

**7**  
Tighten the screw. Note: Ring terminal should face down with the wire exiting at the middle of the intercell connector as shown. Apply grease to connection after securing to battery and reinstall shroud without pinching wire.

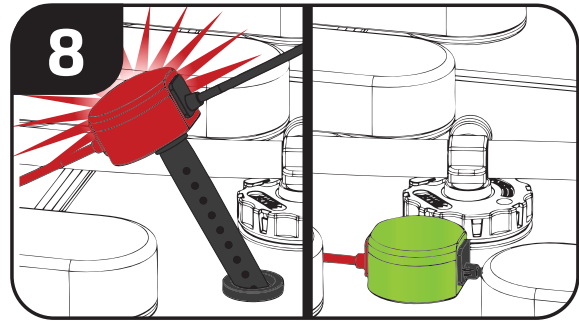

**8**  
The light should now be blinking red. Insert the probe into the grommet. If the electrolyte level is normal, the light will turn to steady green.

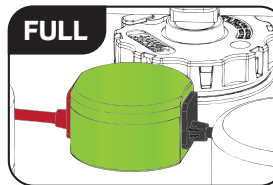

**FULL**  
● Steady green light indicates full water level.

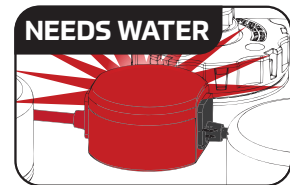

**NEEDS WATER**  
● Blinking red light, it is time to water the batteries.

## Remote Light Installation

Note: The Eagle Eye remote light replaces the light in the main housing, therefore, the main housing light is non-functional.

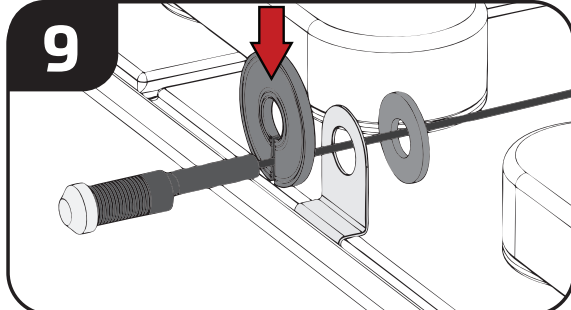

**9**  
Insert bracket between the cell and battery tray on the outside edge of the battery. Insert light through the hole in the bracket and place the slotted washer over the wire as shown.

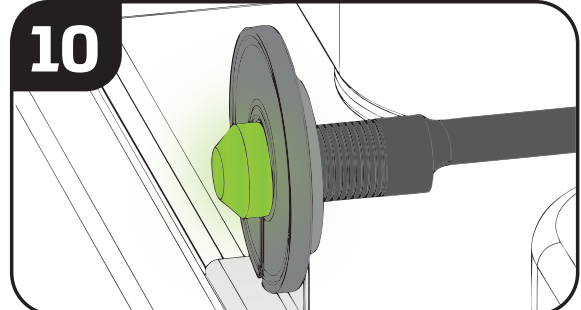

**10**  
Insert bracket between the cell and battery tray on the outside edge of the battery. Insert light through the hole in the bracket and place the slotted washer over the wire as shown.

### **WARNING!**

Failure to follow these instructions or use of unapproved installation equipment may cause injury and permanent damage to the product or battery. Always use personal protection equipment when working on lead acid batteries. Never work on batteries if they are gassing or on charge.

**NOTE:**

- This product is intended to monitor electrolyte levels inside of flooded lead acid batteries. Failure to use this product in the manner intended could compromise safety protection provided by the equipment.
- Probe should be wiped clean and terminals checked for corrosion each time the battery has preventative maintenance.